

4. For models PDM830, PDM830-T, PDM840, PDM840-T, PDM850, PDM850-T, connect one end of the meter lead to the circuit to be measured. Connect the other end of the meter lead to receptacle on recorder panel and observe proper polarity.
5. Plug power line cord into recorder line receptacle and connect to proper line voltage and frequency.
6. Push chart drive switch to "ON" position (exposing the word "ON"). Make sure switch clicks into detent position which locks it into place. See fig. 11.
7. Mark time of start on chart paper. See fig. 8.
8. Secure recorder in a horizontal or vertical position.

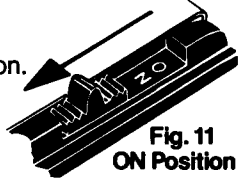

Fig. 11
ON Position

READING STRIP CHARTS

In some cases strip charts have more than one scale. Read on the scale that corresponds to the range you are using. If the particular range you are using does not appear on the chart, use a scale with numbers that you can easily convert to the range you need.

HOW TO USE AS AN INDICATING METER

Follow steps 1, 2, 4 and 5 of "How To Use As A Recorder." With chart paper removed, read directly on scale plate.

SERVICE

Serial number is die stamped in lower right hand corner of the scale plate.

For Factory service, package instrument and packing slip with sufficient cushioning material in a shipping carton; make certain your name and address also appear on box as well as packing slip; ship prepaid via U.P.S. (where available) or Air Parcel Post insured to:

Service Division
AMPROBE INSTRUMENT
630 Merrick Road (Use for U.P.S.)
P.O. Box 329 (Use for Parcel Post)
Lynbrook, NY 11563-0329

Outside the U.S.A. the local Amprobe representative will assist you.

OPERATING INSTRUCTIONS FOR AMPROBE® DC MILLIVOLT RECORDERS

NON-TAKE-UP MODELS:
PDM830, PDM840, PDM850

TAKE-UP MODELS:
PDM830-T, PDM840-T, PDM850-T

See Precautions for Personal and Instrument
Protection on Page 3

See Limited Warranty on Page 2

 **AMPROBE INSTRUMENT®**
DIVISION OF CORE INDUSTRIES INC., LYNBROOK, NEW YORK 11563

LIMITED WARRANTY

Congratulations! You are now the owner of an AMPROBE® instrument. It has been quality crafted according to quality standards and contains quality components and workmanship. This instrument has been inspected for proper operation of all of its functions. It has been tested by qualified factory technicians according to the long-established standards of AMPROBE INSTRUMENT.

Your AMPROBE instrument has a limited warranty against defective materials and/or workmanship for two years from the date of purchase provided that, in the opinion of the factory, the instrument has not been tampered with or taken apart.

Should your instrument fail due to defective materials, and/or workmanship during the two-year warranty period, return it along with a copy of your dated bill of sale which must identify instrument by model number and serial number.

For your protection, please use the instrument as soon as possible. If damaged, or should the need arise to return your instrument, it must be securely wrapped (to prevent damage in transit) and sent prepaid via Air Parcel Post insured or UPS where available to:

Service Division
AMPROBE INSTRUMENT
630 Merrick Road (For U.P.S.)
P.O. Box 329 (For P.P.)
Lynbrook, NY 11563-0329

Outside the U.S.A. the local Amprobe representative will assist you. Above limited warranty covers repair and replacement of instrument only and no other obligation is stated or implied.

sure that feed control is tight and in the right position. The word "ON" must be visible. Press in the idle roller extension © to allow the recording mechanism to move back down into case and lock into position. Replace cover by positioning the "U" bend onto the plastic projections and snap front down. Make sure chart paper is not binding with the cover in place. For "non-take-up" recording, route chart through bottom slot as shown in fig. 9.

4. To remove chart from take-up spindle ①, move the latches away from the take-up spindle. Turn knurled knob on spindle ② until the slot in the take-up drive pulley at the opposite end of the spindle is lined up with the slot in the side frame of the recorder. Slide the spindle and chart up and out of the slots in the side frames of the recorder. Remove tape from chart and bobbin.
5. To unload chart paper from recorder turn chart drive switch off, exposing the word "OFF". See fig. 1. Follow 4 above. Remove chart from feed shaft ③ and pull paper thru recorder.

SELECTING CHART SPEED ON TAKE-UP MODELS

1. To select chart speed, energize recorder with proper line voltage and frequency. Raise recorder to vertical position (see loading and unloading chart paper on take-up models). Move chart drive switch to "ON" position exposing the word "ON". Make sure switch clicks into detent (see fig. 11). Set all three speeds to "OFF" position and tighten (see fig. 9). Move desired speed knob (1, 12 or 24) to "ON" position. Tighten while keeping pressure on gear mechanism.
2. Press in the idle roller extension © to allow the recording mechanism to move back down into the case and lock into position. Replace cover by positioning the "U" bend onto the projections above the chart well opening. Make sure chart paper is not binding with the cover in place. For "non-take-up" recording route chart through bottom slot as shown in figure 9.

HOW TO USE AS A RECORDER

1. Chart drive switch must be in "OFF" position (exposing the word "OFF"). See fig. 1.
2. Remove top cover. Adjust zero setting. (See Zero Adjusting).
3. Load chart paper. See fig. 7 or 9. Replace cover by positioning "U" bend onto the metal projections of chart well (non-take-up) and onto molded plastic projections for take-up recorder and then snap front down. Make sure paper is not binding with cover in place.

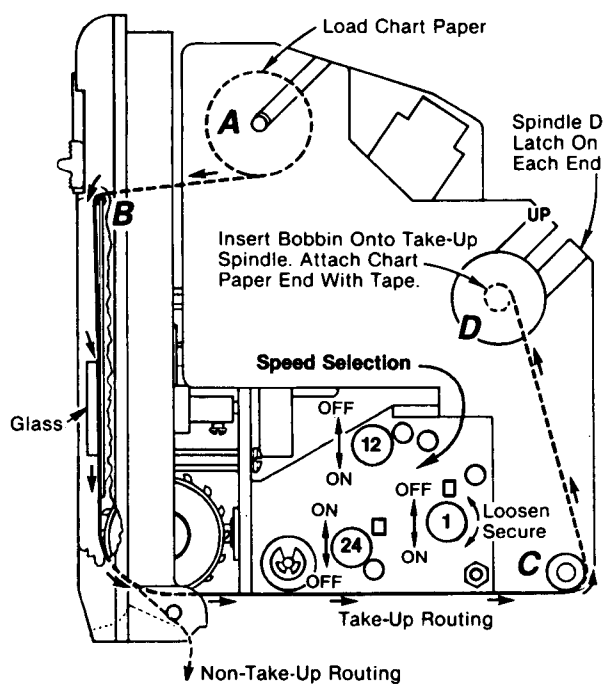
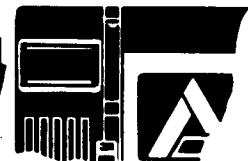

Fig. 9
Take-Up Recorder

LOADING AND UNLOADING CHART PAPER ON TAKE-UP MODELS

1. Move chart drive switch to "OFF" position exposing the word "OFF." See fig. 1.
2. Remove top cover. See fig. 3.
3. To insert or remove chart paper, place recorder in horizontal position and press the release button in the direction shown in fig. 10. Raise recorder mechanism to a vertical position until it locks. Remove feed shaft (A) (see fig. 9) and place chart roll on spindle. Remove tape on roll and retain tape for securing chart on take-up spindle (D). Unroll about 12" to 15" and route paper over top edge of scale plate (B) underneath glass, over the sprocket wheels, to the rear and over the idle roller (C) up to the cardboard bobbin mounted on take-up spindle (D). Secure edge of chart to bobbin with tape. Make sure the sprocket holes in the paper engage the sprocket wheels. Be

Fig. 10



PRECAUTIONS FOR PERSONAL AND INSTRUMENT SAFETY

1. Read these instructions thoroughly and follow them carefully.
2. In many instances you will be working with dangerous levels of voltage and/or current, therefore, it is important that you avoid direct contact with any uninsulated, current-carrying surfaces. Appropriate insulating gloves and clothing should be worn.
3. Before connecting or disconnecting the voltmeter to or from the circuit to be tested, turn off all power to the circuit.
4. Before applying test leads to circuit under test, make certain:
 - a. Proper test leads are plugged into correct instrument jacks, and
 - b. Selector switch is set to proper range.
5. Before using any electrical instrument or tester for actual testing, the unit should be checked on a known live line to make certain it is operating properly.
6. If the instrument should fail to indicate, do not touch circuit until you have checked to see that all instrument switches are in proper position and instrument has been checked on a known live circuit.

IMPORTANT: Failure to follow the instructions or to observe the above precautions may result in personal injury and/or damage to the instrument and/or accessories.

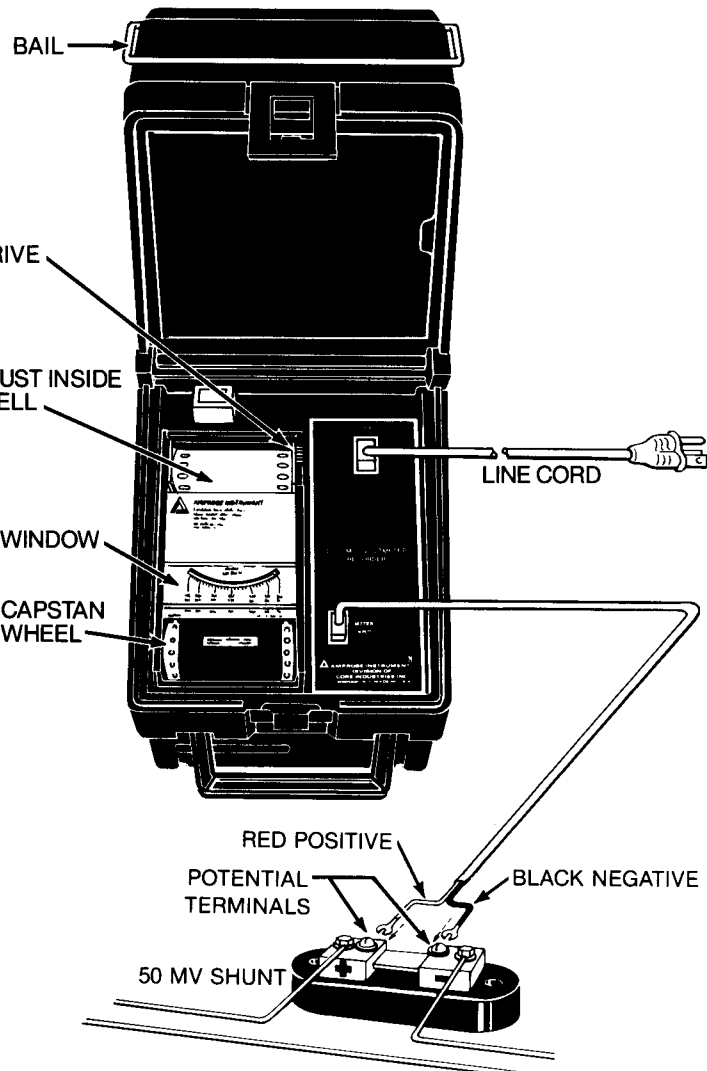

NON-TAKE-UP MODELS: PDM830, PDM840, PDM850

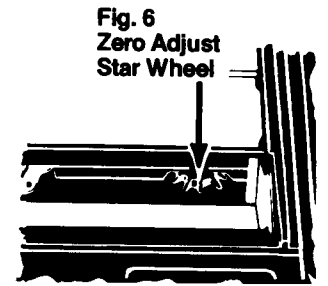

LOADING AND UNLOADING CHART PAPER ON NON-TAKE-UP MODELS

1. Move chart drive switch to "OFF" position exposing the word "OFF." See fig. 1.
2. Remove top cover. See fig. 4.
3. Unroll about nine (9) inches of chart paper.
4. With printed side up, slip leading edge of paper under the glass and out, through slot in front as shown in fig. 7.
5. Make sure the holes on both sides of the chart paper engage the sprockets of both capstan wheels.
6. Line up time arrow (see fig. 8) with any line on the left of the chart paper.
7. To unload chart paper, turn chart drive switch off and remove paper.

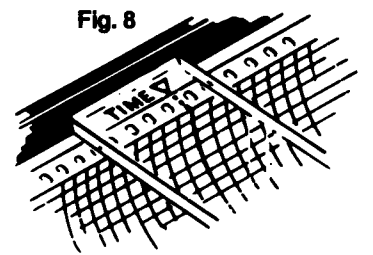
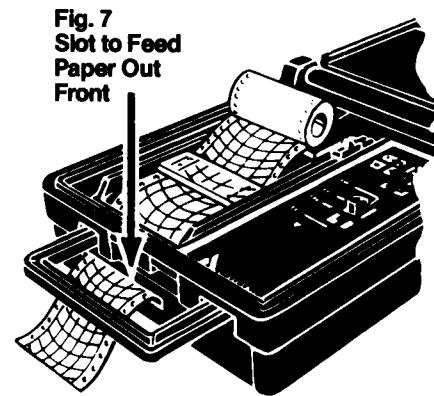

ZERO ADJUSTING

With chart drive switch in "OFF" position (see fig. 1) exposing the word "OFF," check mechanical zero setting of pointer (see fig. 2) before making any electrical connections to the instrument. If adjustments are necessary proceed as follows:

- a) Remove top cover—pull bottom ledge of frame toward you and lift. See fig. 3 or 4.
- b) With strip chart roll not in recorder, locate star wheel. See fig. 5 or 6.
- c) Apply finger to star wheel and turn until pointer lines up with zero mark at the extreme right of scale. See fig. 2.

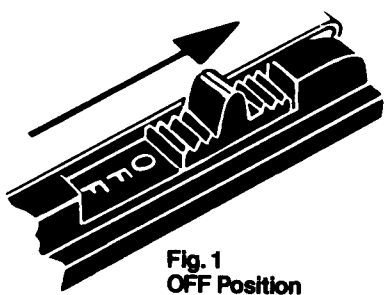

Fig. 1
OFF Position

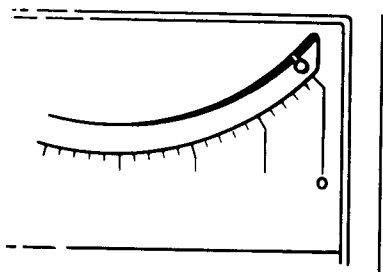

Fig. 2

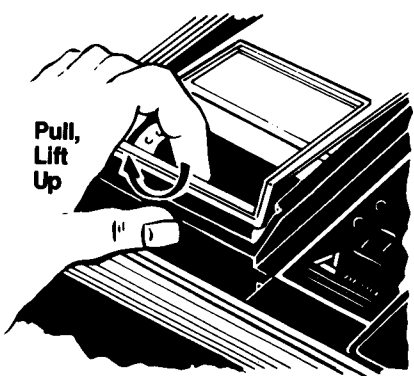

Fig. 3

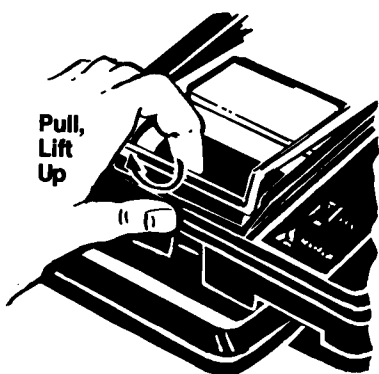
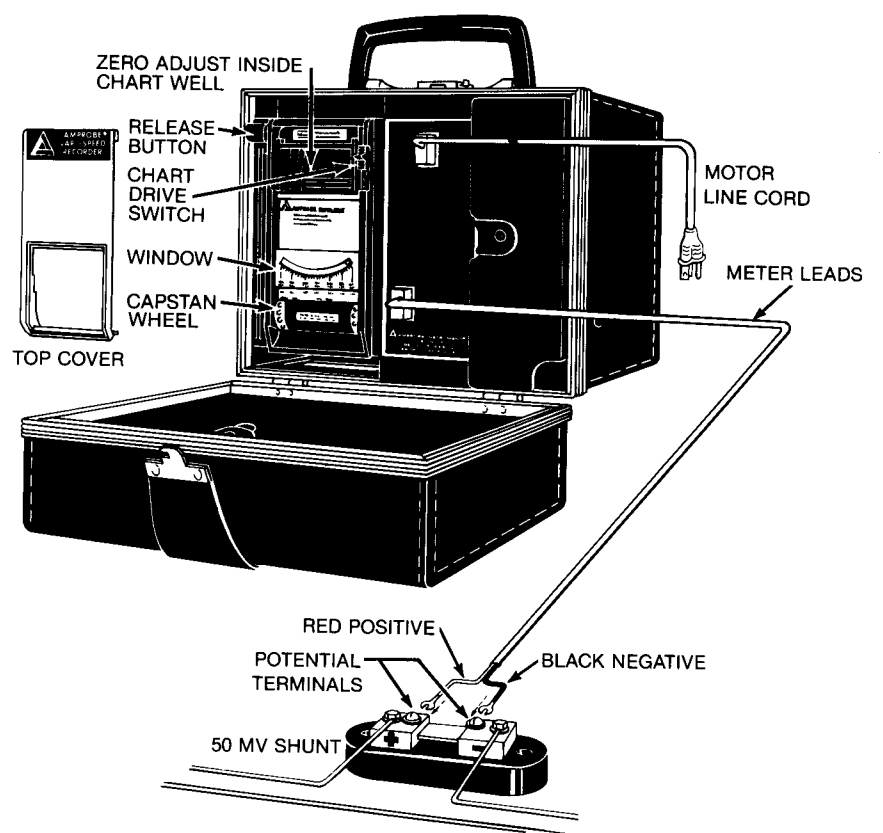

Fig. 4



TAKE-UP MODELS: PDM830-T, PDM840-T, PDM850-T

INTRODUCTION

Models PDM830, PDM830-T, PDM840, PDM840-T, PDM850, PDM850-T are 50mV DC Recorders with scales of 30, 40 and 50 divisions respectively. These instruments are designed for use with 50mV shunts to measure DC current, but can also be used to measure up to 50 Millivolts.

SPECIFICATIONS

Model	Range	Scale Divisions	Chart Paper
PDM830, PDM830-T	0-50mV	0-30	830D, 830D-6*
PDM840, PDM840-T	0-50mV	0-40	840D, 840D-6*
PDM850, PDM850-T	0-50mV	0-50	850D, 850D-6*

* 30 ft. chart supplied; -6 is 60 ft. chart for take-up models only.

Power Requirements: 120 Volts 60 Hz, 3 Watts (unless otherwise stated)

Operating Temperature: 20° F (-6.7° C) to 140° F (60.0° C)

Model	Chart Speed	Imprint Rate
PDM830, PDM840, PDM850	1" (2.54cm)/hr. or 12" (30.48cm)/hr.	1 per min. at 1"/hr. 1 per 5 sec. at 12"/hr.
PDM830-T, PDM840-T, PDM850-T	Variable at 1" (2.54cm)/hr. 12" (30.48cm)/hr. 24" (60.96cm)/hr.	1 per 2.5 sec. at 1"/hr. 12"/hr., 24"/hr.